

# HOLD DOWN BAR INSTALLATION

## UNIFORM MOVER

1. Hold down bar and links are pre assembled.
2. If not the bar will need to be removed and ends switched and reinstalled.
3. Install hold down bar so that handle is on the outside. See drawing for location of bar and fasteners. Install fasteners in links only (3). Tighten then back off nut until bar moves freely.
4. Install 1/4" screw, plain nut and lock nut. Tighten plain nut securely. Install 1/4" lock nut in position shown.
5. Install spring.
6. Repeat for other side.
7. Installation is complete.

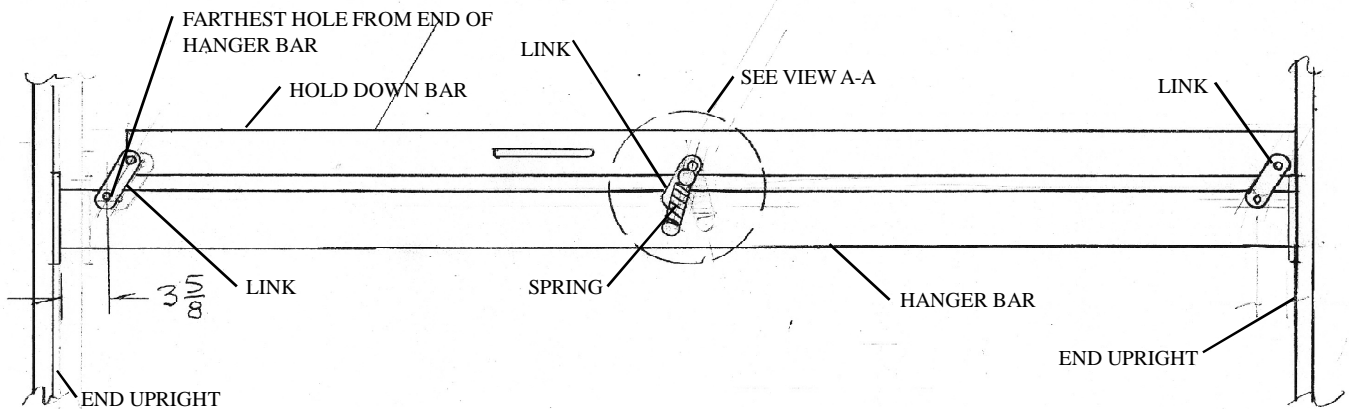
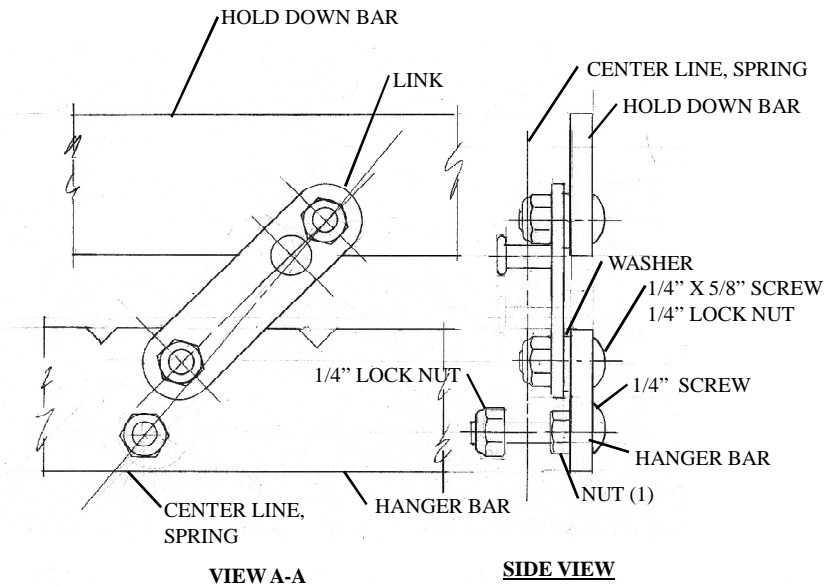

**IF FURTHER ASSISTANCE IS REQUIRED PLEASE CALL 1.800.548.4239**