

PERCUSSION RACK W/ SWING ARMS ASSEMBLY INSTRUCTIONS

TOOLS REQUIRED

9/16" WRENCH

1/2" WRENCH

1. Assemble the tie rod to frames. See VIEWS I & III. Note: Both frames are identical. Assemble both frames with the JARVIS logo to the outside. This will orient the frames correctly, since the round frame uprights are not in the middle of the square tubing.

2. Install the two cross clamps and the main tubing to the two frame uprights. See VIEW I. Note: The cross clamps may be installed to hold the main tubing on either side of upright. However, both should be on the same side. See VIEW II.

3. Install the diagonal brace using the fasteners attached. See VIEW I.

4. Lay the frame assembly on its side and install the four casters using the 5/16" bolts, washers and nuts (16 ea.).

5. Set frame upright and install the swing arms by sliding arms down on the frame upright. The long portion of the swing arm tee must go on first. Swing arm should rest on tapered bushings.

6. Tighten all fasteners securely. Assembly is complete.

7. Install instrument clamps as required to hold your instruments.

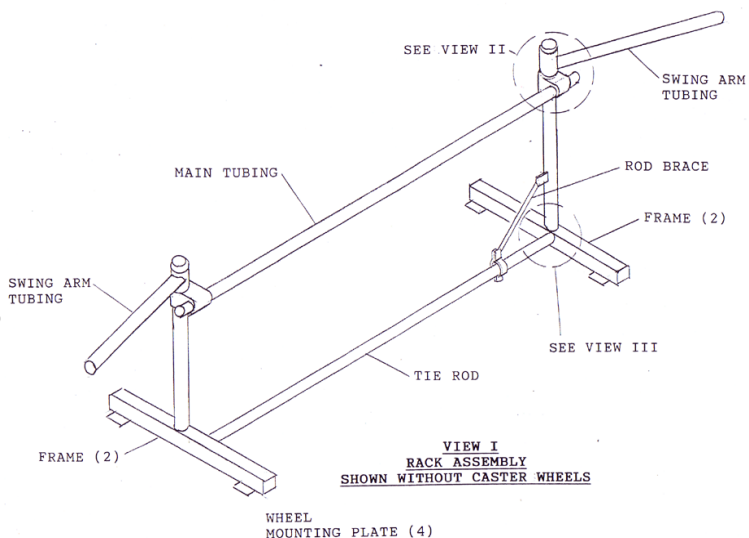

VIEW I
RACK ASSEMBLY
SHOWN WITHOUT CASTER WHEELS

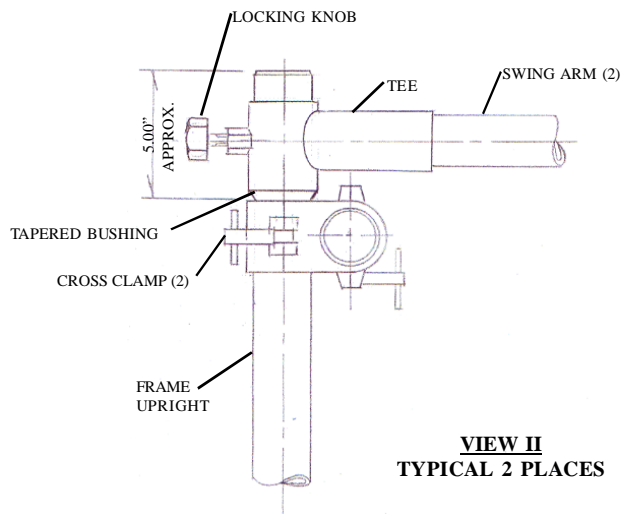

VIEW II
TYPICAL 2 PLACES

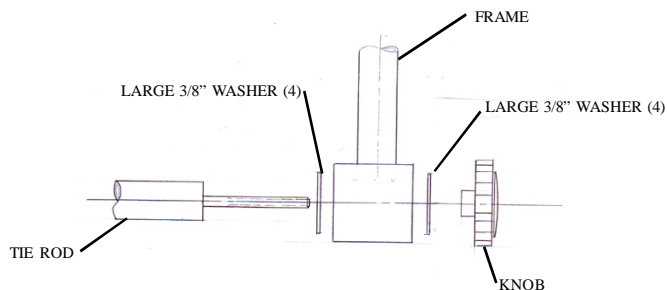

VIEW III
TYPICAL 2 PLACES