

# MOBILE PERCUSSION RACK ASSEMBLY INSTRUCTIONS

## FRAME & TIE ROD ASSEMBLY

Assemble the LH & RH Frames with the two tie rods using the knobs and washers as shown in **View B-B**. The knobs are self-locking. It will be necessary to hold the tie rod or the opposite knob while tightening.

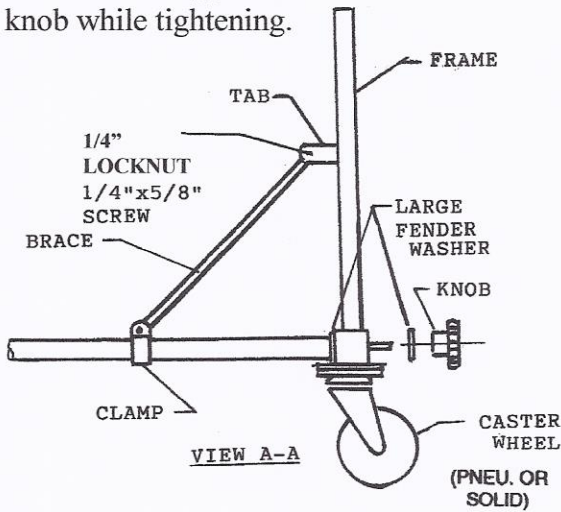
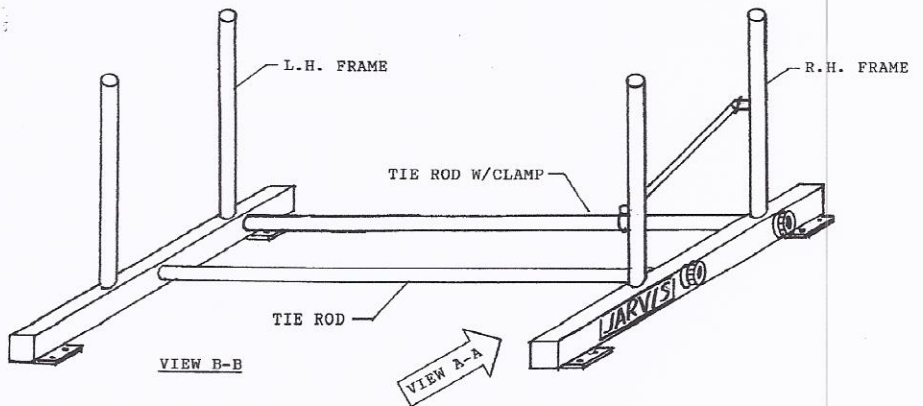

## BRACE INSTALLATION

Install the brace. See **View A-A** for positioning of brace. Also, see drawing below for further installation instructions including hardware.

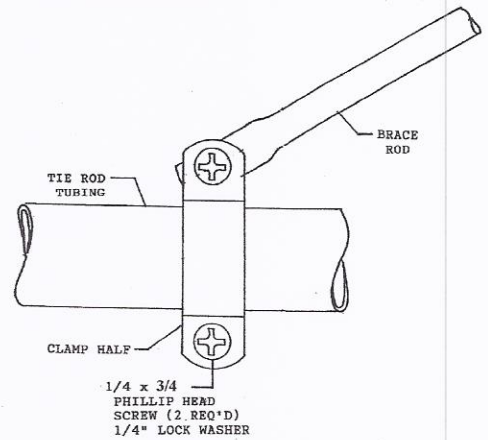

TYPICAL CLAMP & BRACE ROD INSTALLATION

## PERCUSSION TUBING INSTALLATION

- Install the 6 ft. long Aluminum tubing, using two of the 1-1/2" right angle clamps. See **View C-C**. Install the clamp approx. 3" from the top of the round vertical tubing. The aluminum tubing may be installed on the near or far side of the vertical tubing. See **View C-C**.
- Install one of the two-3 ft. long aluminum tubing using two of the 1-1/2" right angle clamps. The tubing may be installed in one of 2 different positions. See **View C-C**.
- Installation as shown on the right side of **View C-C** will allow the aluminum tubing to swing closed when clamp 'E' is loosen and the tubing is removed from clamp 'F'.

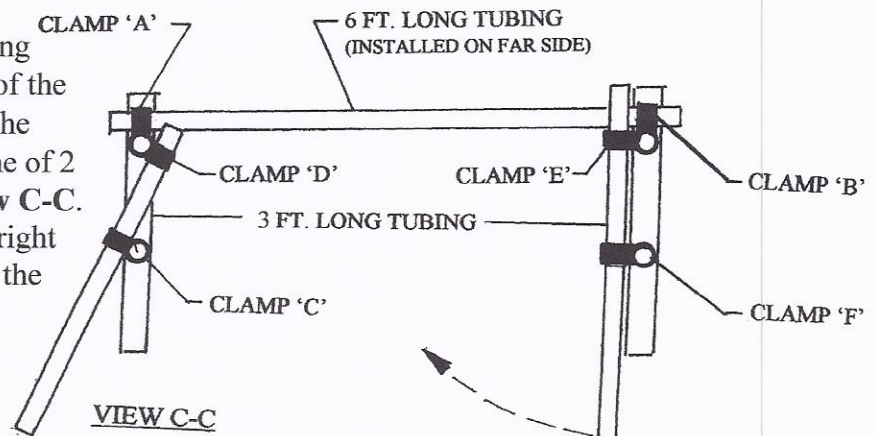

- The closed position will provide for smaller storage space & easier passage through doorway.
- Installation as shown on the left side of **View C-C** will "open up" the center of the rack assembly providing more room for the player.
- Install the instrument clamps as required for your particular instruments.