

BASS DRUM STAND ASSEMBLY INSTRUCTIONS

TOOLS REQUIRED:
 1/4" DRILL BIT
 7/16 WRENCH
 DRILL MOTOR
 #2 PHILLIPS SCREWDRIVER

NOTE: DUE TO THE LARGE VARIATIONS IN DRUM SUSPENSION, CABLES ARE NOT PROVIDED.

SUSPENSION KIT ASSEMBLY

If not purchased please skip to the assembly instructions located on the flip side of this page.

1. DETERMINE WHICH TYPE OF DRUM SUSPENSION YOU REQUIRE. IF YOU REQUIRE THE TYPE WITH EYEBOLTS, MARK THE LOOP TO MATCH DRUM LOCATIONS AND DRILL A HOLE FOR THE EYEBOLTS, **SEE DETAIL II** (THIS TYPE SIMILAR TO YAMAHA)

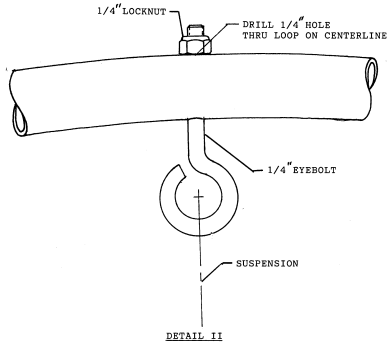

2. IF YOU REQUIRE THE TYPE WITH ELASTIC SUSPENSION, INSTALL CLAMPS AND LUGS AS REQUIRED, THE LUGS ARE INSTALLED BETWEEN THE CLAMP STRAPS. THE LUGS ARE INSTALLED BETWEEN THE CLAMP STRAPS. THE LUG WITH ONE HOLE IS TO BE INSTALLED AT THE END OF SUSPENSION RUN. THE TWO HOLE LUGS ARE INSTALLED BETWEEN THE SUSPENSION ENDS, **SEE DETAIL I**. (THIS TYPE IS SIMILAR TO LUDWIG.)

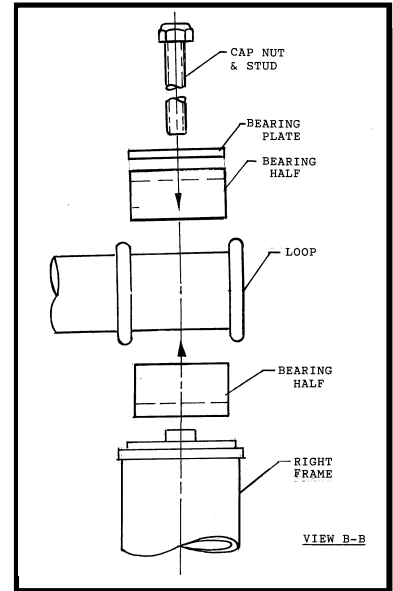
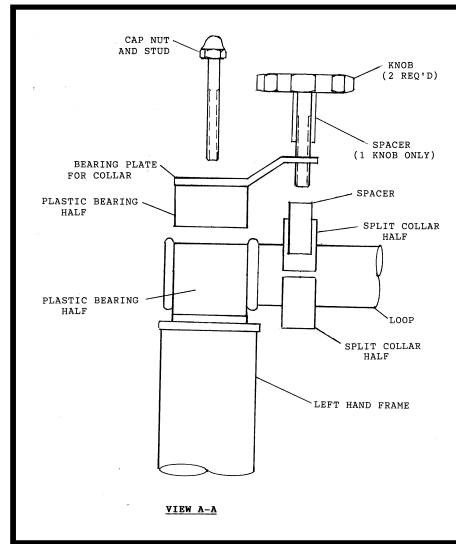
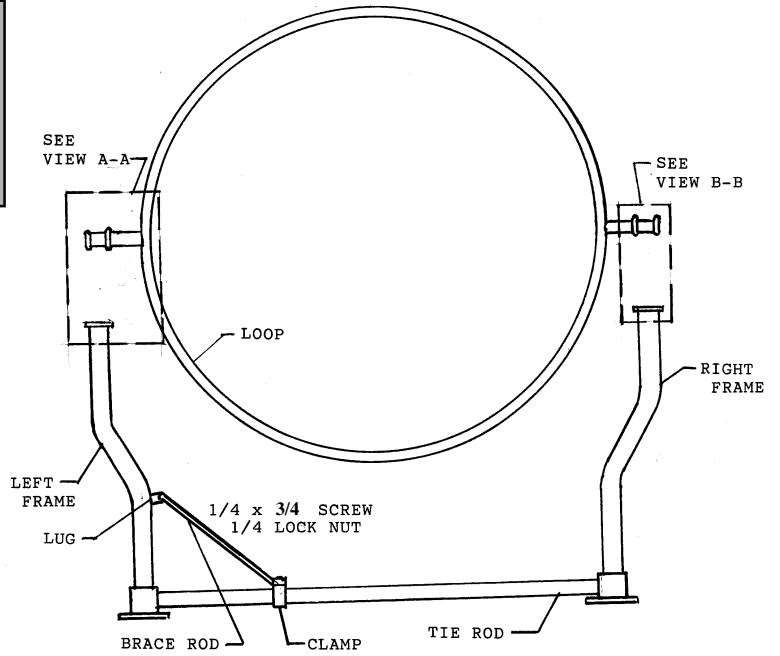
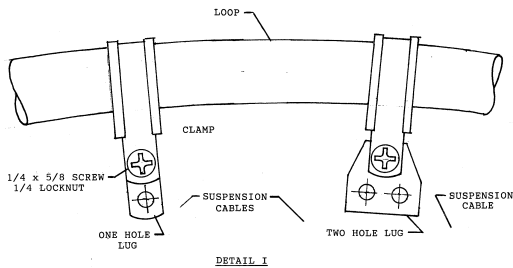

FRAME ASSEMBLY

1. INSTALL THE TIE ROD BETWEEN THE TWO FRAMES, THE CLAMP ON THE TIE ROD MUST BE INSTALLED NEAR THE FRAME WITH THE TIE ROD LUG. **SEE DETAIL III.** THE KNOBS ARE THE SELF-LOCKING TYPE AND WILL REQUIRE HOLDING THE TIE ROD WHILE TIGHTENING.

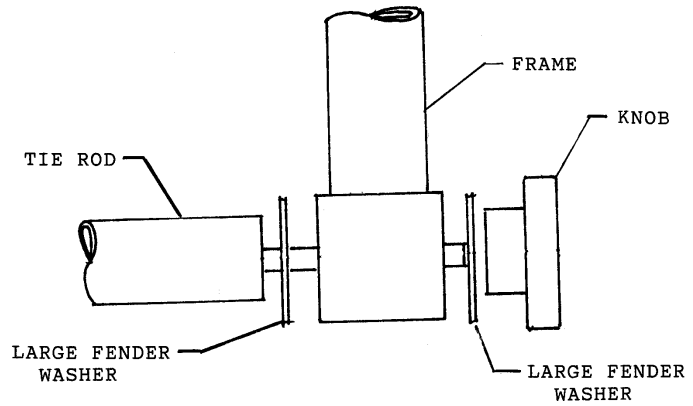

DETAIL III
(TYPICAL 2 PLACES)

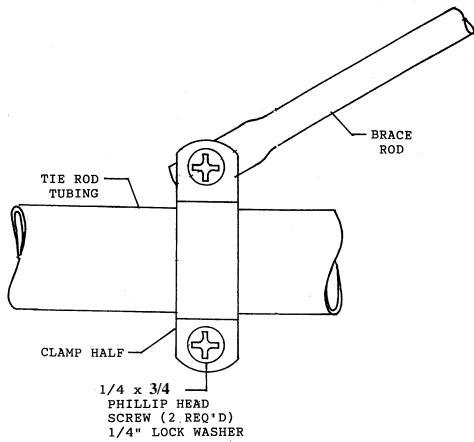

TYPICAL CLAMP & BRACE ROD INSTALLATION

2. INSTALL THE BRACE ROD. **SEE DETAIL**
3. INSTALL ONE BEARING HALF ON EACH FRAME. PUSH DOWN FIRMLY.
4. SET LOOP INTO BEARING HALVES, ON RIGHT SIDE INSTALL TOP BEARING HALF, BEARING PLATE AND TWO (2) CAP-NUT STUDS.
5. REMOVE BOTTOM HALF OF SPLIT COLLAR. KEEP KNOBS AND SPACERS INTACT WITH BEARING PLATE. INSTALL BEARING PLATE, (WITH KNOBS & SPACERS) BOTTOM OF SPLIT COLLAR AND TOP BEARING HALF ON LEFT SIDE OF FRAME. DO NOT TIGHTEN KNOBS. TIGHTEN THE TWO (2) CAP-NUT STUDS, DO NOT OVER TIGHTEN. WITH LITTLE EFFORT THE LOOP SHOULD REVOLVE. TO PREVENT THE LOOP FROM TURNING, TIGHTEN BOTH KNOBS.
6. INSTALL THE CASTER WHEELS WITH 16 CARRIAGE BOLTS AND NUTS.
7. TIGHTEN ALL BOLTS AND NUTS. **DO NOT OVER TIGHTEN**
8. *YOU ARE NOW READY TO USE YOUR DRUM STAND.*

IF YOU NEED FURTHER ASSISTANCE PLEASE CALL: